

# LET'S PAINT - ART LESSONS: PERSPECTIVE



## ADDITIONAL RESOURCES AND PRACTICE SHEETS

Use these pages as a way to help you practice painting fundamentals from the lesson while having fun creating art.

For more inspiration and education please visit [plaidonline.com/lets\\_paint](http://plaidonline.com/lets_paint)



INSPIRATION PAINTING

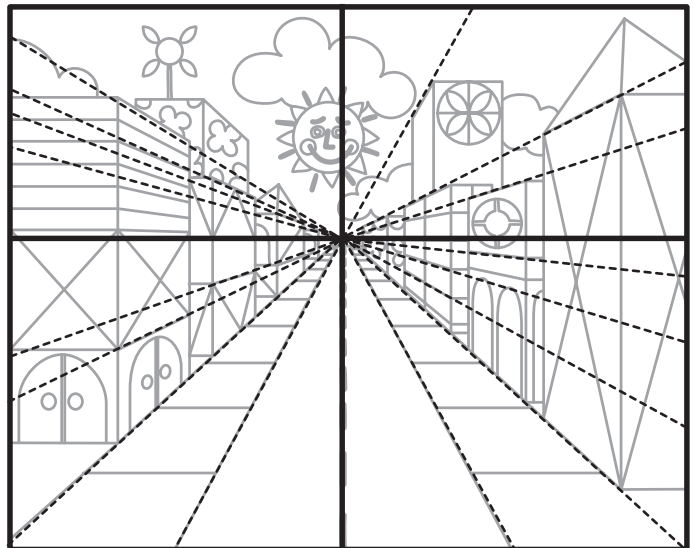

PERSPECTIVE LINES

Perspective is the ability to add depth and space to a two-dimensional surface. Perspective makes things look three dimensional and creates a sense of space receding into the distance. There are typically three types of perspective drawing: one-point perspective, two-point perspective, and three-point perspective.

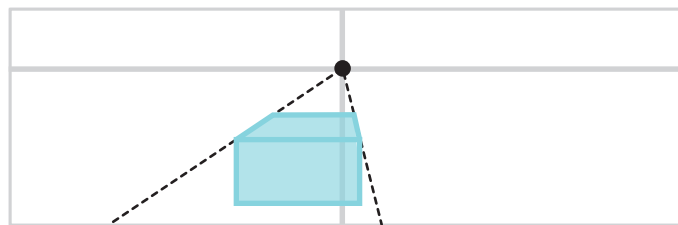

ONE-POINT PERSPECTIVE

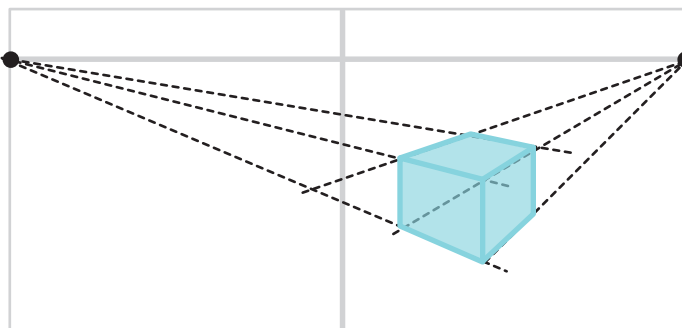

TWO-POINT PERSPECTIVE

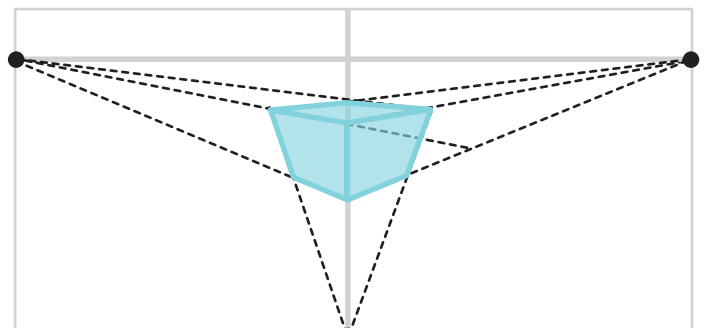

THREE-POINT PERSPECTIVE

# LET'S PAINT - ART LESSONS: PERSPECTIVE



## EXERCISE - PERSPECTIVE 1

**Vanishing Point:** The point in space where items seem to disappear.

**Horizon Line:** Horizontal line that is considered eye level that's drawn across the picture.

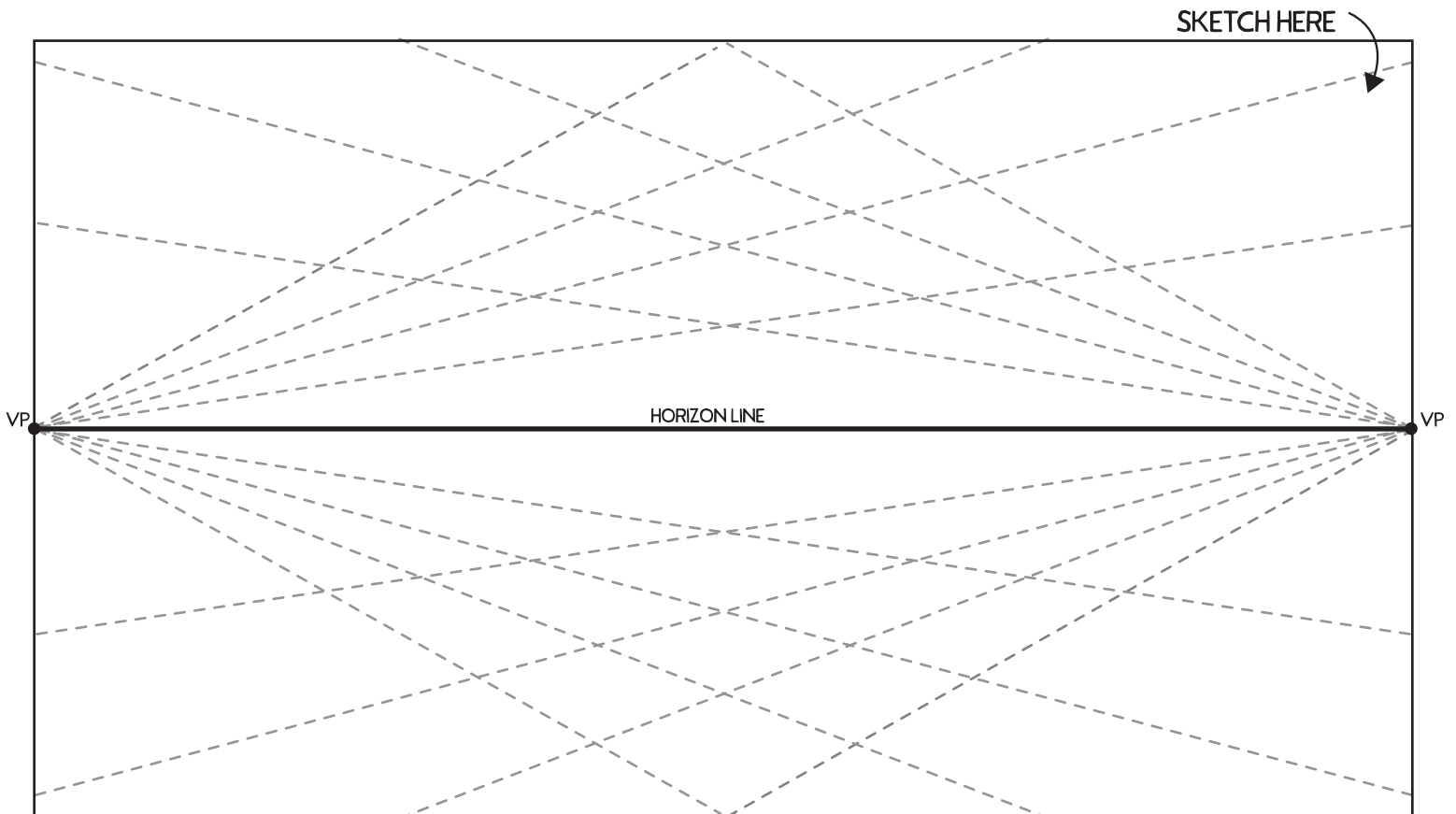
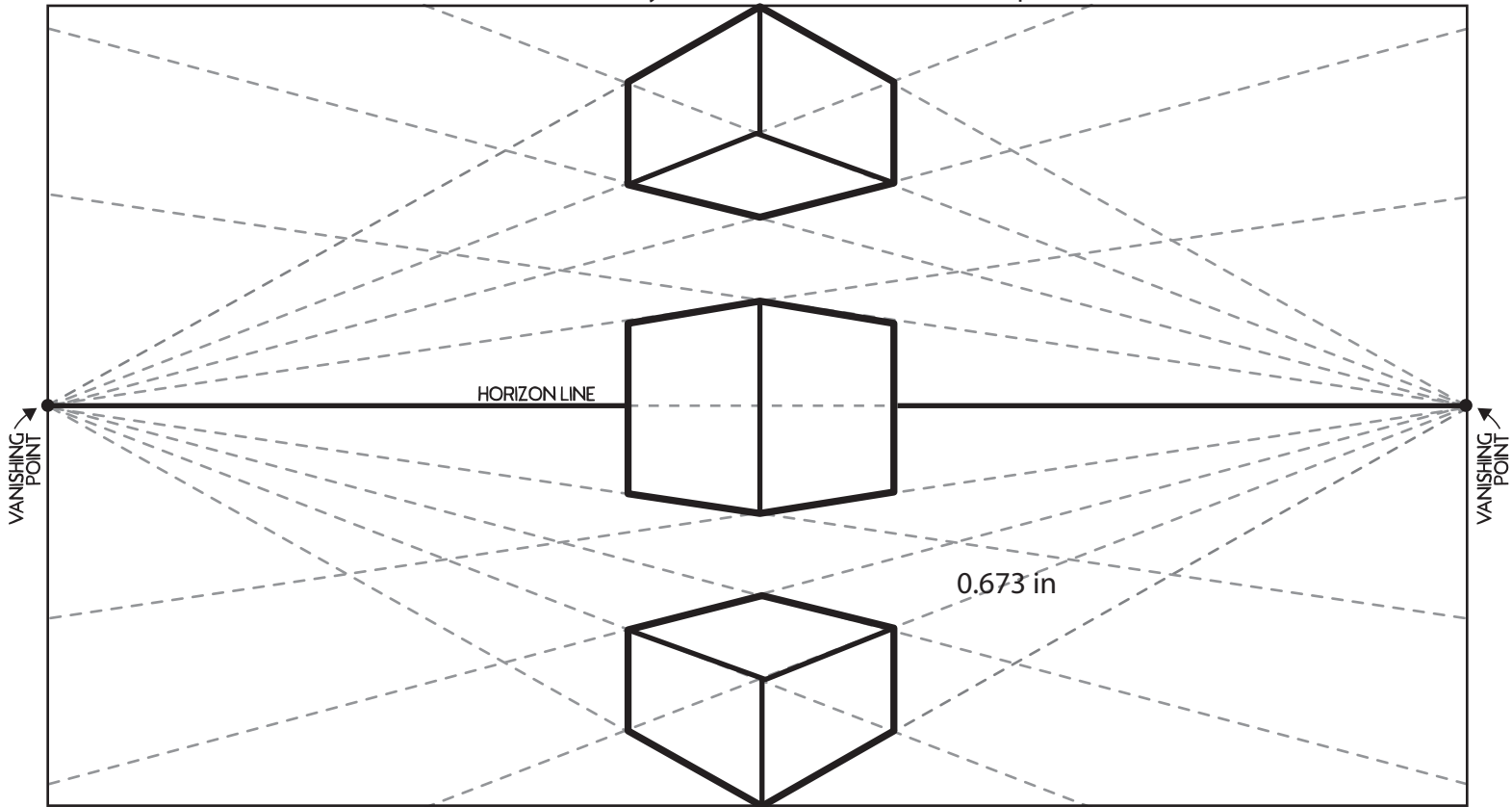

# LET'S PAINT - ART LESSONS: PERSPECTIVE



## EXERCISE - PERSPECTIVE 2

**Vanishing Point:** The point in space where items seem to disappear.

**Horizon Line:** Horizontal line that is considered eye level that's drawn across the picture.

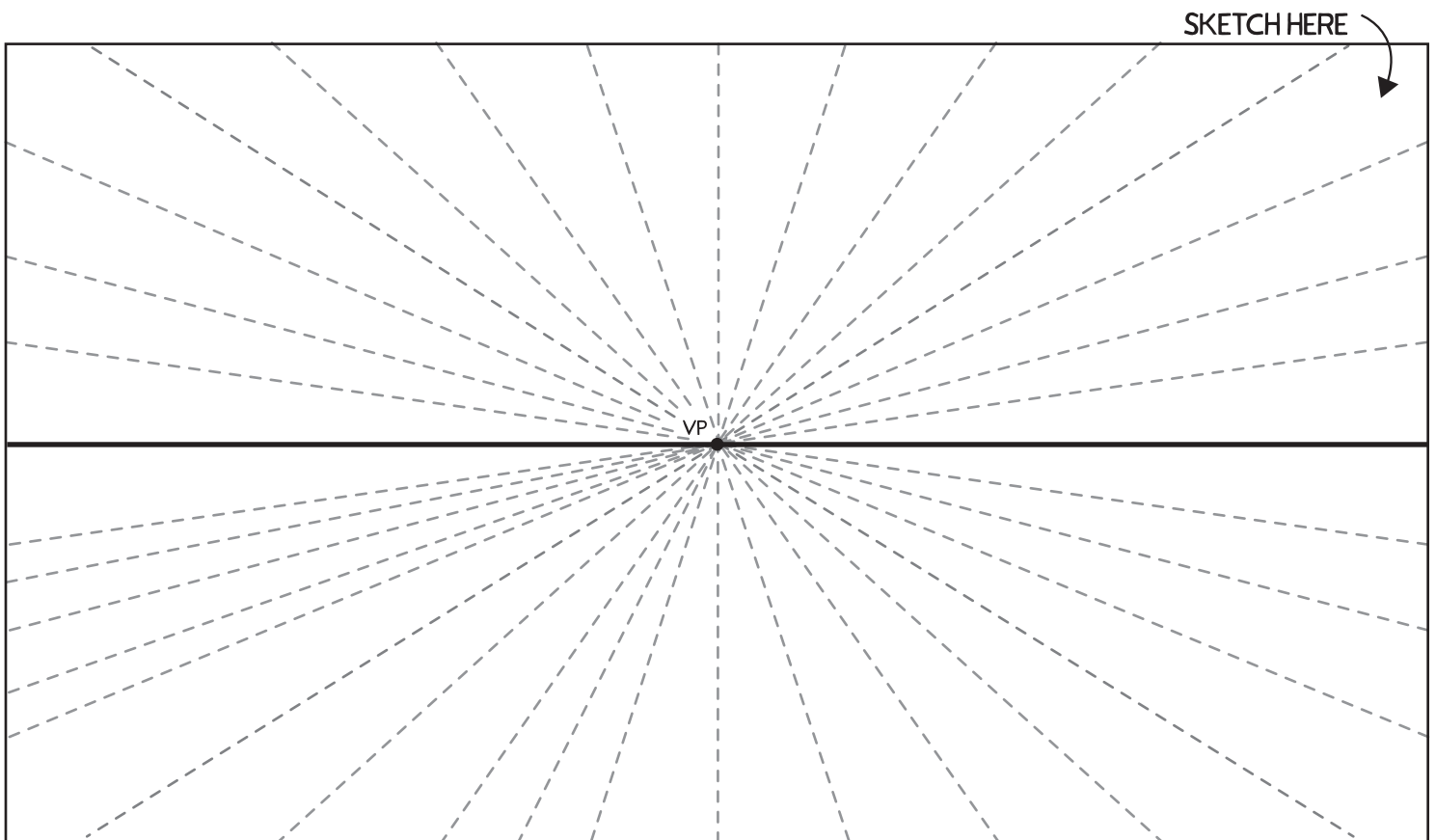
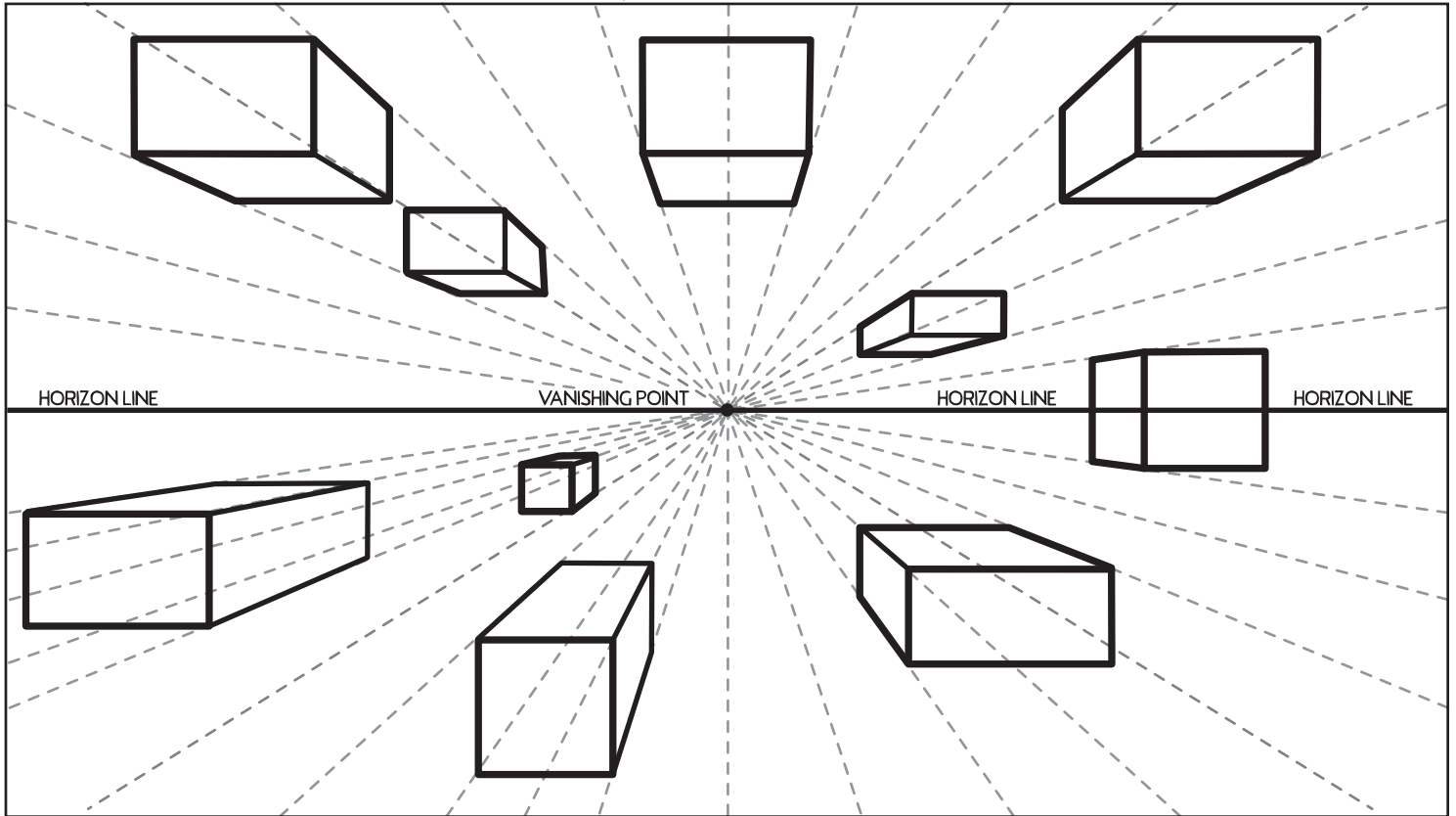

# LET'S PAINT - ART LESSONS: PERSPECTIVE



## EXERCISE - PERSPECTIVE 3

**Vanishing Point:** The point in space where items seem to disappear.

**Horizon Line:** Horizontal line that is considered eye level that's drawn across the picture.

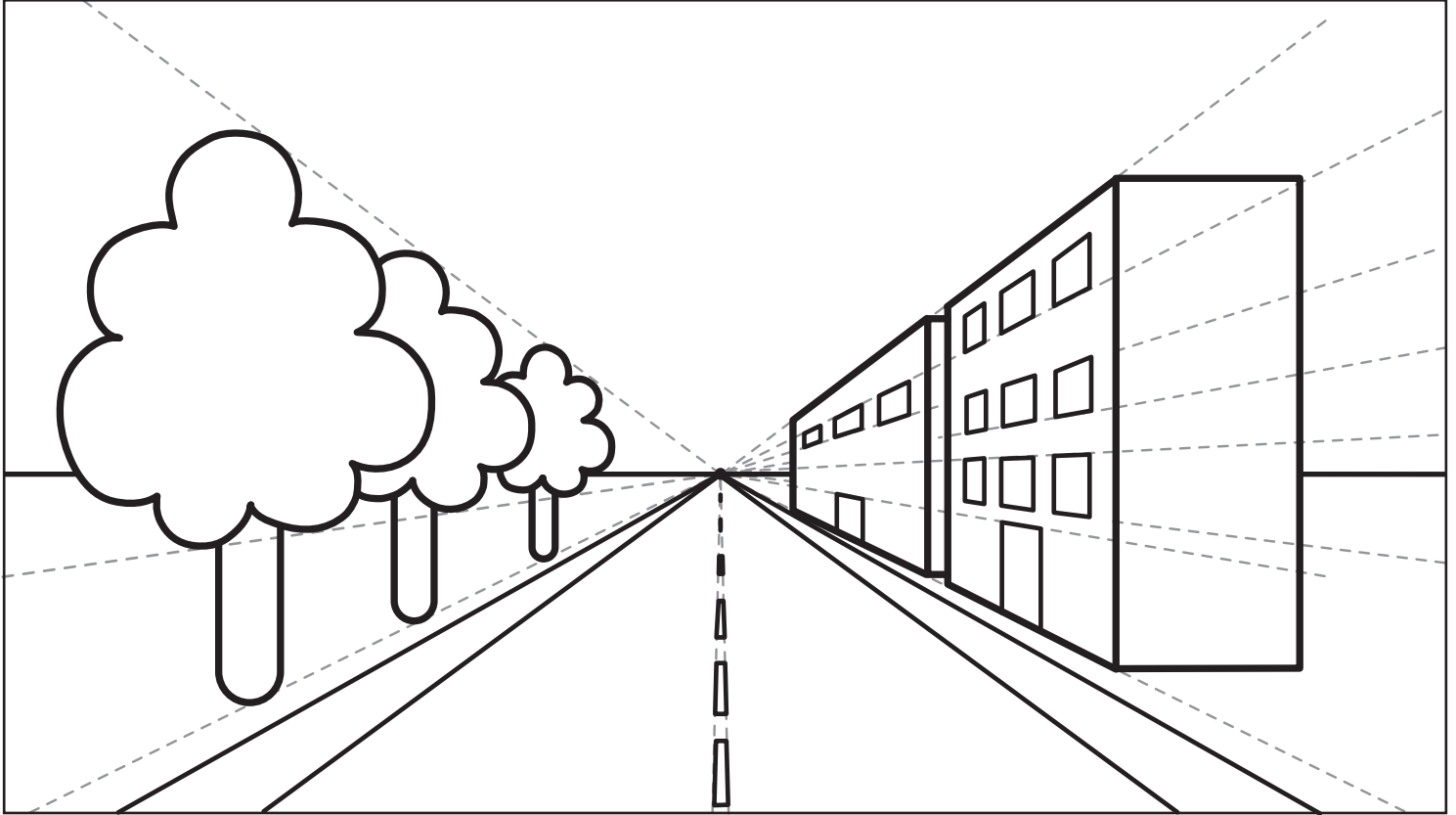

SKETCH HERE

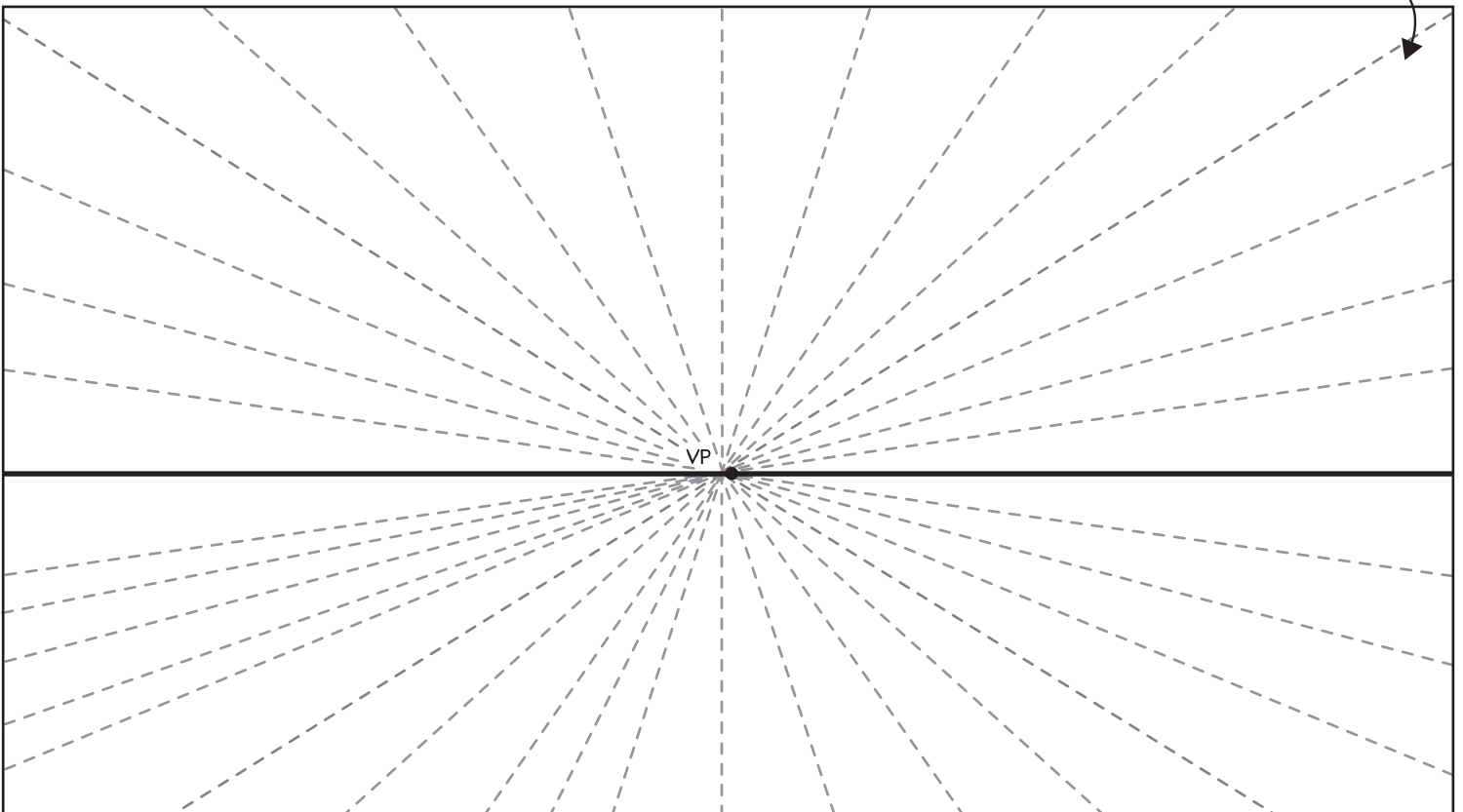





# LET'S PAINT - ART LESSONS: PERSPECTIVE

## EXERCISE - PERSPECTIVE 4

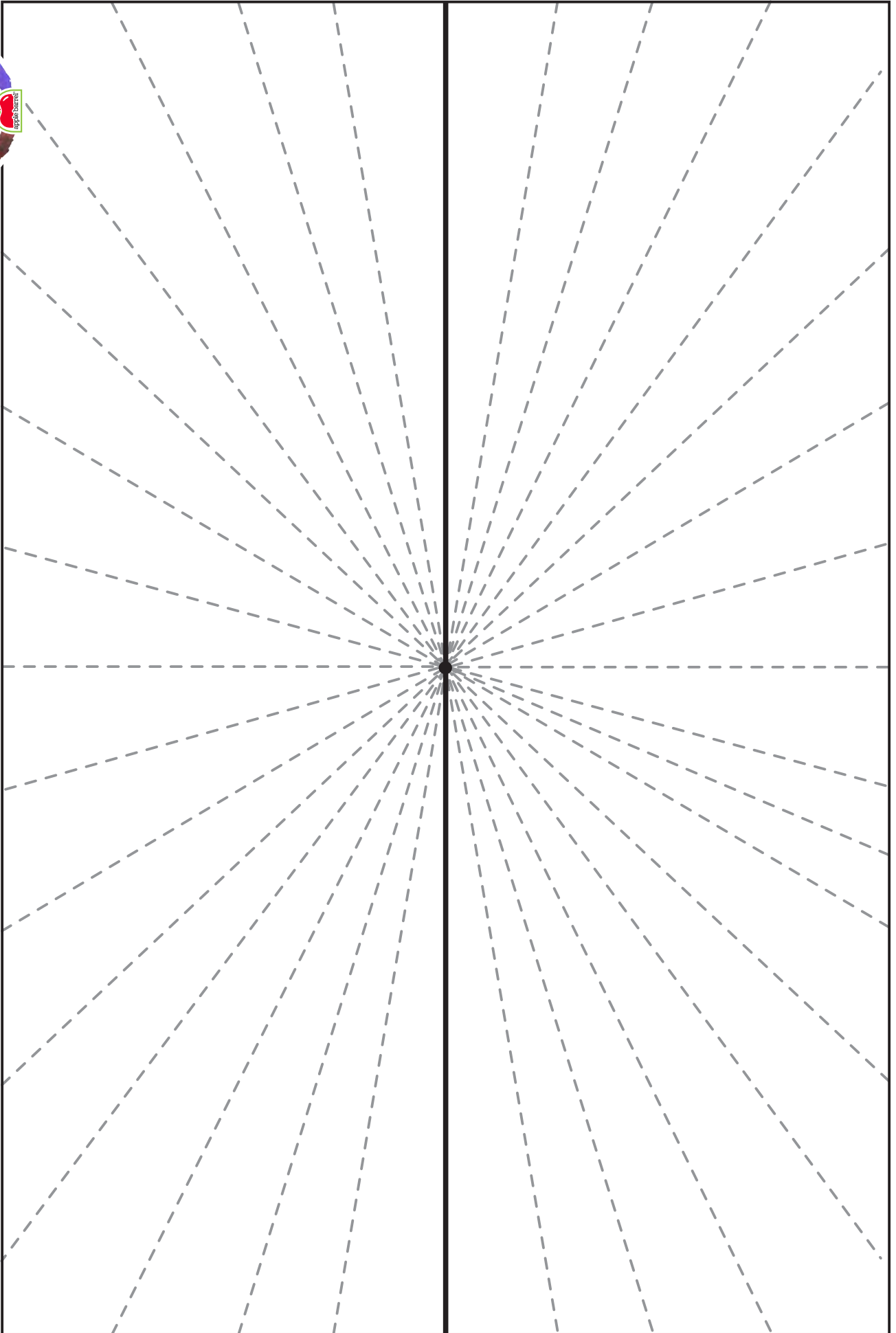

FOR PERSONAL USE ONLY

© 2022 Plaid Enterprises, Inc. Norcross, Georgia, USA. All rights reserved.